

SE•200D

DIGITAL
WIRELESS
MICROPHONE
SYSTEM



OPERATING MANUAL

Please read this manual carefully before use.

CONTENTS

Brief Introduction.....	1
Main Features.....	1
Parts (Receiver).....	2
Receiver Display.....	3
Handheld Mic Operation.....	6
Receiver Operation.....	8
Technique Specification.....	10

1. BRIEF INTRODUCTION

This digital wireless system adopts intelligitized cryptographic hardware. Unique sound and RF performance.

With optional professional recharge accessories.
Endurable rechargeable lithium batteries.

Frequencies grouping, colorful TFT LCD and humanized menu make it easy for single or multi-sets mounting.

2. MAIN FEATURES

- UHF band (660-690 Mhz).
- Digital audio transmission technology.
- Unique digital 16 bit ID pilot technology,
no crosstalk disturbance even at the same frequency.
- Ultra-short audio latency.
- 48 KHz audio.
- Frequency response: 30-20000 Hz.
- Colorful TFT display and menu settings.
- Auto frequency scanning and spectrum display.
- Working distance: 40 m.

3. PARTS (RECEIVER)

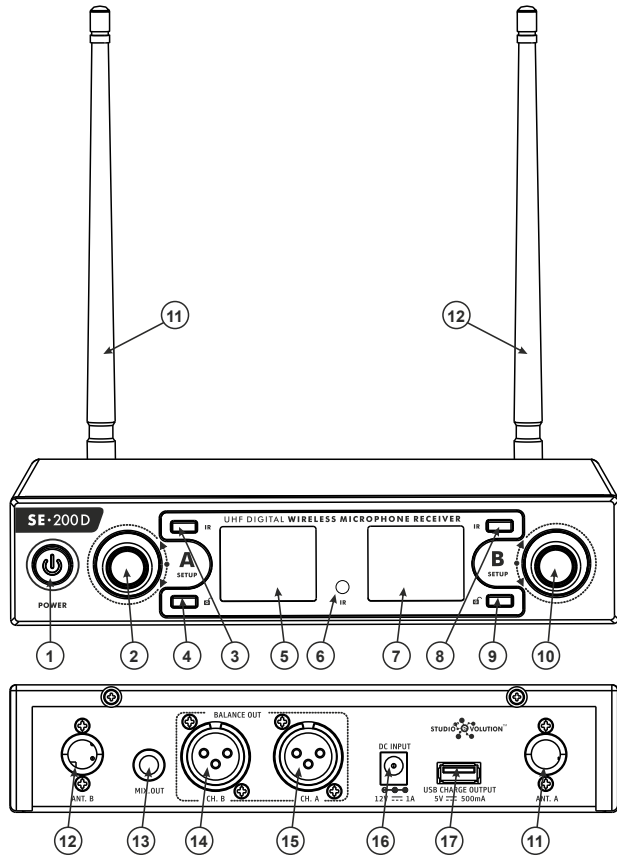

- | | |
|------------------|-----------------------|
| 1. POWER | 10. SETUP B |
| 2. SETUP A | 11. ANT-A |
| 3. IR (infrared) | 12. ANT-B |
| 4. UNLOCK | 13. MIX.OUT |
| 5. TFT DISPLAY | 14. BALANCED OUT B |
| 6. IR (infrared) | 15. BALANCED OUT A |
| 7. TFT DISPLAY | 16. DC INPUT |
| 8. IR (infrared) | 17. USB CHARGE OUTPUT |
| 9. UNLOCK | |

4. RECEIVER DISPLAY

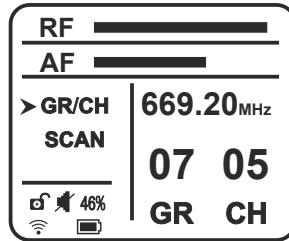

RF  RF: Indicate signal intensity, the longer length of the color, the stronger signal.

AF  AF: Indicate audio level, the longer length of the color, the stronger signal.

GR/CH GR: Group: Number above the icon indicates the current frequency group.

CH: Channel: Number above the icon indicates the current group frequency.

SCAN
UP
DOWN Auto scan. Automatically scan up or down to search for available frequency until the desired frequency is reached. Can be set under SCAN function.

 Lock status, the buttons are inefected under this status.

 Mute, indicates Receiver is under MUTE status.

46% Indicate the current voice volume of Receiver, adjustable range is 0%-100%.

 IR icon, when flashing indicates now is sending SYNC signal.

 Battery icon, indicates the handheld microphone battery status during charging.

- Display during operation.

When the receiver is working, long press UNLOCK to unlock the system before settings. Begin from channel adjustment details are below.

Note: the below setting is under unlock status, long press UNLOCK before setting.

- Channel setting mode.

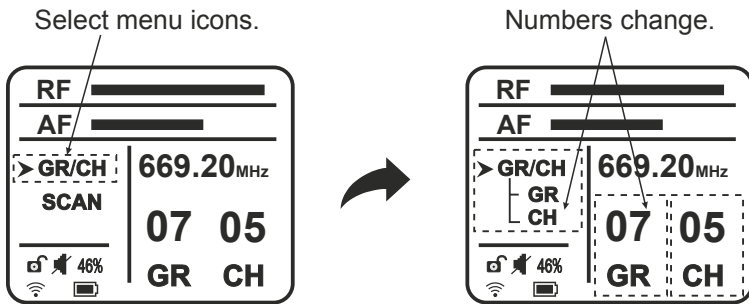

Press setup knob to enter into the channel setting mode. Chose GR/CH by rotating the knob. Press it for confirmation .

Then adjust the control knob to select the appropriate menu item (GR or CH). Select the appropriate group or channel by knob rotation.

Press the control knob to confirm the appropriate channel, finally press IR function for synchronization with microphone.

- Scan available channel mode.

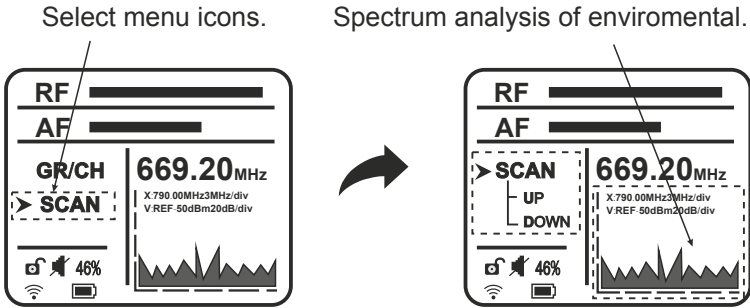

Adjust SETUP control knob, press SCAN function enter into scan available frequency mode. Then adjust the control knob, select UP or DOWN can automatically scan up or down to search for available frequency until the desired frequency is reached. This function is convenient for user to find the available frequency quickly under different situation.

- Volume setting.

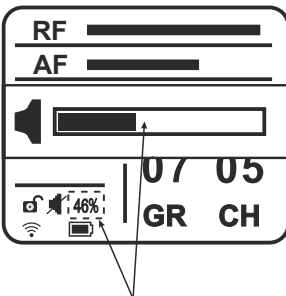

Voice volume.

Rotate SETUP control knob to adjust the Receiver voice volume, visually showed by Bar chart and % number.

5. HANDHELD MICROPHONE OPERATION

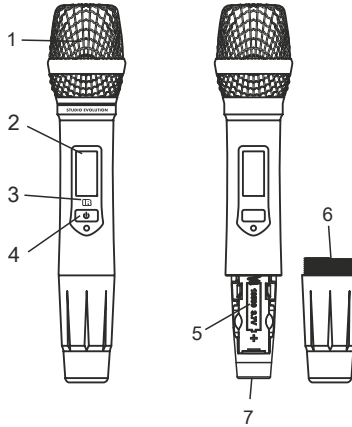

1. Microphone capsule: convert sound to electrical signal.
2. LCD display: indicates the microphone working information.
3. SYNC window: use to receive IR signal, from Receiver IR window .
4. ON/OFF switch: controls ON/OFF power and mute function.
5. Battery Sink: insert 1x18500 lithium battery, note to insert it in correct polarity.
6. Mic cap: unscrew it when change battery.
7. Micro-USB socket for charging (DC, 5 volts).

▶ HANDHELD MICROPHONE LCD

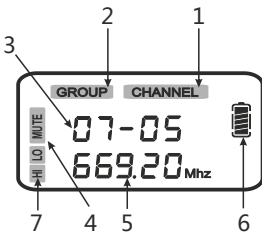

1. **CHANNEL** Indicates below working channel
2. **GROUP** Indicates below working group
3. **07-05** Indicates Group 7, Ch05
4. **MUTE** Indicates mute status
5. **669.20 Mhz** Indicates current using frequency (811,5MHz)
6.  Indicates battery status, flashing indicates battery low power
7. **HI LO** HI or LO indicates high or low transmission power

Remove the battery cover, insert 1x18500 Lithium battery in correct polarity.

Long press ON/OFF button in 3 sec, if LCD not light, check whether battery in correct polarity or battery is low of power. If the battery indicator of LCD display is flashing, please change with new battery.

The microphone can only work under the same frequency with Receiver.

- To synchronize the microphone with receiver:
 1. Unlock A or B.
 2. Press IR (receiver).
 3. Put microphone IR in front of receiver IR.
 4. Check if the same channel is indicated on microphone and receiver displays.

Note! The SYNCHRONIZATION period is within 30 seconds.

After switching ON, the microphone automatically enters the default mode and automatically uses the last saved channel.

HANDHELD MICROPHONE USING TECHNIQUE

Don't hold the microphone Grille:

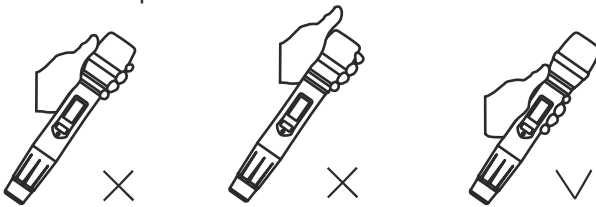

Avoid holding the microphone on antenna position:

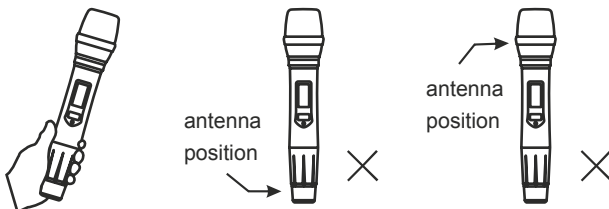

- Don't use two microphones together:
- Attention: the using distance between the microphone Grille and mouth needs to be less than 15cm.
- Avoid microphone location in front of loudspeakers.

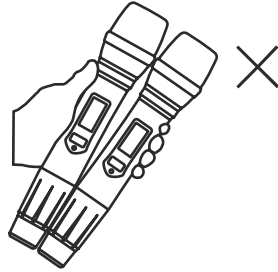

6. RECEIVER OPERATION

- Pull out the antenna (11), (12), make them to be perpendicular to the receiver.
- Connect the power adapter (12V 1A, positive central contact) to the DC socket (16) of the Receiver before using. Make sure, that the adaptor is suitable for the Receiver.
- Connect the audio cable:
 Mix output: connect the audio cable (purchased additionally) to the MIX. OUT socket (13) while the other side connect to INPUT socket of the mixer or amplifier.
 Balance output: connect the balance audio cable (attached) to the BALANCE socket (14/15) while the other side connect to INPUT socket of the mixer or amplifier.
- Connect the USB charge cable:
 Connect the charge cable (attached) to the USB socket (17) while the other side connect to the handheld microphones.

Notes! • You may charge microphones by another 5V chargers (for smartphones).

- During charging the microphone doesn't work!
 - Do not charge non-rechargeable batteries!
- Turn on the power button (1), LCD display (5,7) will shine. Receiver is in working status. Note: Before turn off the Receiver, turn the volume control knob (2,10) to the minimum volume. Adjust the volume as you need after next turning on.

Select function by adjusting the SET UP knob (2/10) (Function details refer to the Instruction of Receiver TFT display function).

See below IR SYNC picture, long press IR button under unlock status, Receiver start sending signal, automatically turn to work after completion.

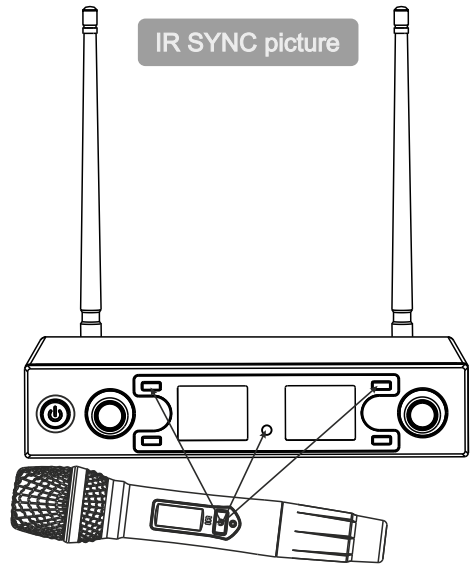

Long press IR button, start sending signal while signal icon flashing. Turn on handheld microphone, put the IR window in front of the Receiver IR window. Signal icon disappears when devices are connected by IR. Shown frequency need to become the same on handheld microphone and on Receiver displays.

► Recommendations of Receiver installation.

- The distance from the receiver to walls or to floor needs to be not less than 1 meter. Otherwise, antennas efficiency will decrease and working distance will be reduced.
- Pull out antennas vertically for better signal receiving.

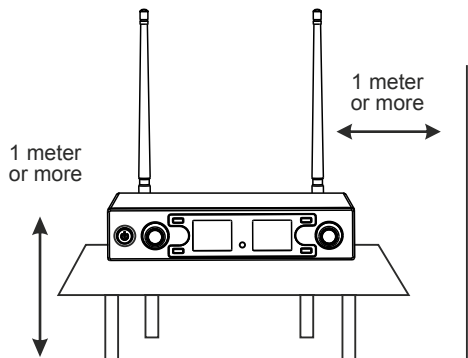

7. TECHNIQUE SPECIFICATION

RECEIVER

Carrier Frequency: UHF660-690 MHz
Bandwidth: 30 MHz
Channel Bandwidth: 300 KHz
Preset Group: 15 group, 6 frequencies in each group.
Dynamic Range: 96 dB
Distortion: <0.1%
Frequency Response: 30-20 KHz / +2 dB
Signal/Noise Ratio: 96 dB
Receiving Sensitivity: -95 dBm
Transmission Delay: <3 ms
Power Supply: DC 12V 1A
Audio Outputs: 1 x TRS 6.3 mixed A+B,
2 x XRL Balanced A/B

MICROPHONE

Carrier Frequency: UHF660-690 MHz
Bandwidth: 30 MHz
Frequency Switch: IR SYNC
Output Power: 9 mW
Harmonic Radiation: <-50 dBc
Battery: 1x18500 Lithium
Battery operation before recharging: >8 h

Content List

1. Receiver x 1
2. Handheld Microphones x 2
3. Antiroll rings x 2
4. Audio Cable x 2
5. Charge Cable x 1
6. Power Adapter x 1
7. 18500 Rechargeable Battery x 2
8. Manual x 1



WWW.STUDIO-EVOLUTION.COM